

Finnex®

HPC SERIES

QUARTZ GLASS AQUARIUM
HEATER WITH GUARD

Thank you for purchasing a Finnex HPC series aquarium heater. Our heaters are constructed of the finest materials for outstanding reliability and performance. Please read and follow all the instructions for proper set-up and use contained in this guide. If you require assistance, please contact us at:

✉ Customer_service@finnex.net

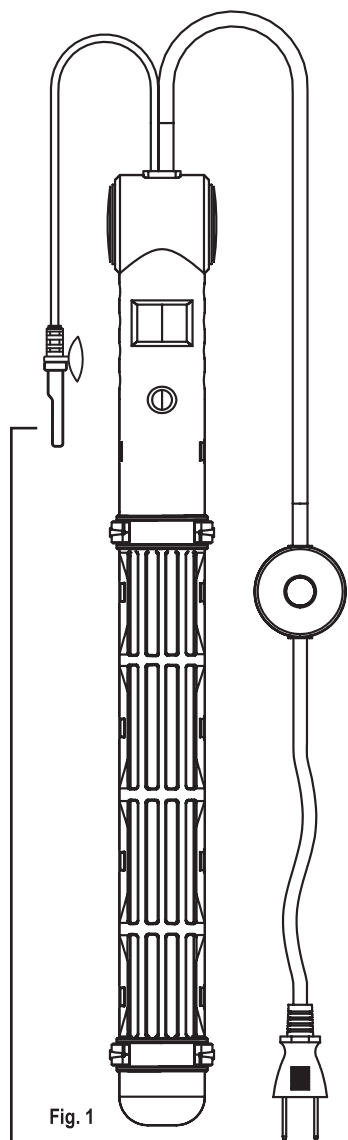

Fig. 1

Clean and confirm the out-of-water sensor is functioning properly every 30 days. DO NOT USE heater if out-of-water sensor is inoperative.

Important Safety Instructions

Warning: To guard against injury, basic safety precautions should be observed, including the following:

1. Read and follow all safety instructions and all the important notices on the heater before using. Failure to do so may result in loss of fish life and/or damage to this heater.
2. **DANGER** – To avoid possible electric shock, special care should be taken since water is employed in the use of aquarium equipment. For each of the following situations, do not attempt repairs yourself; return the heater to Finnex for service or discard the heater.
 - a. If the heater shows any sign of damage, immediately unplug it from the power source.
 - b. Carefully examine the heater after installation. Prior to installation, carefully check and make sure the components appear in working order.
 - c. Do not operate any equipment if it has a damaged cord or plug, if it is malfunctioning or it is dropped or damaged in any manner. The power cord of this heater cannot be replaced; if the cord is damaged, the heater should be discarded immediately. Never cut the cord or try to repair it.
 - d. To avoid the possibility of the heater's plug or receptacle getting wet, position the heater to one side of a wall mounted receptacle to prevent water from dripping on to the receptacle or plug. A "drip loop" (see figure #2.) should be arranged by the user for the cord connecting appliance to a receptacle. The drip loop is that part of the cord below the level of the receptacle, to prevent water traveling along the cord and coming in contact with the receptacle. If the plug or receptacle does get wet, DON'T unplug the cord. Disconnect the fuse or circuit breaker that supplies power to the appliance. Then unplug and examine for presence of water in the receptacle.
3. This heater is not intended for use by persons (including children) with reduced physical, sensory or mental capabilities, or lack of experience and knowledge, unless they have been given supervision or instruction concerning use of the appliance by a person responsible for their safety. Children should be supervised to ensure that they do not play with the appliance.
4. To avoid injury, do not touch hot parts.
5. **CAUTION:** Always unplug or disconnect all appliances in the aquarium from electricity supply before carrying out maintenance. When inserting or removing the heater from the water, always pull out the electricity plug. Do not remove the heater from the water until it has been allowed to cool for at least 15 minutes. Never yank cord to pull plug from outlet. Grasp the plug and pull to disconnect. Always unplug an appliance from an outlet when not in use.
6. This is an aquarium heater. Do not use it for other than the intended use (i.e.: don't use this heater on swimming pools, garden ponds, bathrooms, etc.). The use of attachments not recommended or sold by the appliance manufacturer may cause a dangerous situation.
7. This heater is suitable for **INDOOR** use only. Do not install or store the heater where it will be exposed to the weather or to temperatures below freezing.
8. Make sure that the heater is securely installed before operating it. The heater must be completely immersed in water. This aquarium heater must never operate outside of water. The heater must never operate without the heater guard.
9. If an extension cord is necessary, a cord with proper rating should be used. A cord rated for less amperes or watts than the heater rating may overheat. Care should be taken to arrange the cord so that it will not be tripped over or pulled. The connection should be carried out by a qualified electrical installer.
10. For added safety, this product must be plugged into a receptacle controlled by a GFCI (ground fault interrupter) circuit breaker
11. **SAVE THESE INSTRUCTIONS!**

HPC Series Overview

The HPC heater series uses an advanced digital processor that monitors and controls the water temperature in your aquarium. The heating controller receives temperature data from the remote sensor in the aquarium. The remote sensor contains no bi-metallic contacts to arc, corrode or wear out. This allows HPC heaters to have precise control, keeping the water temperature stable while avoiding wide temperature swings common with low-quality aquarium heaters. The built-in display lets users know the current temperature, allowing you to easily make temperature adjustments with the control button positioned on the power cord.

The remote sensor also functions as an automatic power cut-off switch. If the water level drops too low and exposes the temperature sensor to the air, power to the heater is turned off. This prevents over-heating of the aquarium, saving your prized aquarium life from harm. The HPC series 2mm thick quartz glass also features a protective heater guard to prevent aquatic life from accidentally coming in contact with the heating tube.

Model	Water Volume	Wattage	Amperage (115V)	Control Range	Heater Length
HPC-100	20-30 Gallons	100 Watts	0.90A	68°F - 92°F	10.25 inches
HPC-200	60-80 Gallons	200 Watts	1.35A	68°F - 92°F	12 inches
HPC-300	80-100 Gallons	300 Watts	2.70A	68°F - 92°F	13.75 inches



Installing & Setting Up The Heater (Read Before Operating)

We recommend filling the aquarium with water that is close to the desired temperature you are trying to achieve. This will make the initial set-up faster and easier. To ensure even and thorough distribution of warm aquarium water and to provide accurate temperature readings, the heater and remote sensor must be placed near a source of water movement. Using the suction cups, mount the heater near an aquarium filter, wave maker or other area of constant water movement. The heater can also be placed in a filter sump. The remote sensor should be mounted underwater, just above the heater tube.

1. Position the heater in the aquarium or sump and press suction cups firmly against glass. **Important:** Position the heater where water can freely flow around the tube to ensure even heat dispersion. Do not forcefully position the heater in locations that put pressure on the heaters endcaps and power cord.
2. Position the remote sensor slightly above the heater tube. This allows the sensor to monitor temperature and detect a low-water condition.
3. Allow heater to acclimate to the aquarium water temperature for 15 minutes before plugging it into the electrical outlet. **Important:** Form a drip loop to ensure that water cannot travel along the power cord and into the electrical outlet - see figure #2.
4. After 15 minutes, plug in the heater and set the water temperature. Refer to "How To Set The Water Temperature" below.

Warning: The heater must never be operated outside of the aquarium. If the remote sensor is exposed to air, the controller will turn off the heater unit and need to be re-set to once the heater and sensor are placed in water. When removing the heater from the aquarium, disconnect the heater from the electrical outlet and allow it to cool down for 15 minutes.

How to set the water temperature

When the heater is plugged in, the controller will display the current temperature. The desired water temperature can be raised or lowered by 1 degree increments.

1. Press the control button **once**. The display will start flashing, indicating it is in adjustment mode.
2. Using the same control button, adjust the temperature to display your desired temperature.
3. Once adjusted to your desired temperature, the display will stop flashing and show the current water temperature. **Note:** The controller will automatically save the setting and return to normal operation if no further adjustments are made after 5 seconds.

A red LED will be displayed whenever the heater is switched on to heat. The red LED will turn off once the aquarium water has reached the desired temperature. If the aquarium is filled with very cold water, it will take longer for the heater to warm the water. In cold water the heater will cycle on and off while raising the water temperature.

Low water warning system

If the water level drops below the out of water sensor, it will automatically shut off the heater. Error code "EE" will be displayed.

To resume normal operation the sensor must first be submerged in aquarium water. The heater will then automatically resume to function as normal.

***Low water warning system functions between 58°F - 92°F. Outside of 58°F - 92°F, the low water warning system is disabled. If the heater does not resume normal operation after being fully submerged back in water, attempt a hard reset by unplugging the heater from the outlet, wait 10 seconds, and plug the heater back in.**

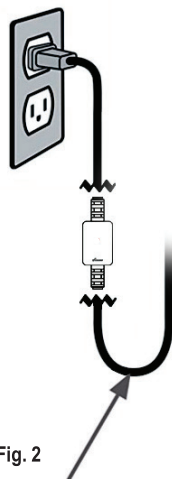

Fig. 2
DRIP LOOP

Proper maintenance and troubleshooting

The heater and remote sensors should be free of algae, debris, calcium carbonate deposits and coralline algae to function properly. Use a soft brush to keep the sensor and heater free of build-up. To remove stubborn mineral build-up, disconnect the heater from the electrical outlet and allow it to cool for 15 minutes. Soak the heater and sensor in vinegar for about 30 minutes then gently brush away the loose mineral scale. Rinse and re-install the heater in your aquarium.

Troubleshooting the heater

Error Code EE: Sensor has been exposed to air or water level has dropped below the safe zone. Fully submerge the sensor.

The controller does not display any information. Check the power cord. Check the circuit breaker or GFCI. Contact Finnex if this condition continues

Heater is fully submerged and still displays EE. In lower temperature conditions, a hard reset may be required after being initially tripped. To do this, unplug the heater for 10 seconds and plug it back in.



FINNEX Limited Warranty

FINNEX's warranty gives certain rights and may also have other rights, which may vary from state to state. Warranty is given only to the end-use purchaser of the accompanying product (referred to in this warranty as "The Product")

What is covered?

Products are warranted by JSK Merchandising Inc. To the original purchaser against defective material and workmanship under normal use for a period of 180 days from the date of the original purchase.

What Is Not Covered?

Products have no warranty if: 1) the product has been serviced, modified or tampered with by anyone other than JSK Merchandising Inc., 2) the product has been abused or damaged, 3) the product has been transported without the proper packaging.

Improper Application - Units are intended for indoor aquarium use only!

Application for anything but the noted is not recommended and voids warranty coverage.

Dry Burns - Dry burning the heater tubes are not covered. This can occur when your heating element is not fully submerged beneath water. Exposing the heating element to air while heating will cause a dry burn which will not be covered.

Water Damage - Water damage to the heater controller will be void of their warranty.

Abuse - Applications other than standard indoor aquarium use. If product is determined to have been abused beyond specifications intended for, warranty will not be in effect. Extreme conditions, including application in outdoor ponds, unheated home i.e. garage and/or basements are categorized as abuse.

Tampered Items - Items opened or items that appear to be manipulated in any way will be void of their warranty.



Warning: Production Dates and Dealer Lots are revealed via serial numbers contained in heater's IC. Identifying a Production Date and Dealer Lot different from the product shown on the receipt will result in a loss of return. If unit does not fall under warranty, item will be destroyed by Finnex after seven days from initial notice unless return shipping is paid by returnee.

What JSK Merchandising Inc., will do

If the product proves defective under the coverage of this warranty, JSK Merchandising Inc. will, at its option, repair or replace on an exchange basis, the product with the same or similar model. JSK Merchandising Inc. reserves the right to supply refurbished replacement products provided that the replacement products conform to the manufacture's specifications for new products. The repaired or replacement product will be returned to you at no cost.

Limitations:

This warranty is limited to repair or replacement of this product, the warranty does not cover personal injury, property loss, including livestock or any direct, indirect incidental or consequential damages or specific relief. Warranty is void for products sold and or used outside the United States of America. Returns for services from area other than the lower 48 states of the USA, customers must pay both way of shipping and additional fees may apply.

What to do if you believe your product is defective?

To initiate a warranty claim, please gather the following documentation. The name of the product, a receipt indicating the date and place of purchase, a detailed description about the problem that is occurring, and the steps you have already taken as described on the troubleshooting page.

Direct the requested information here:

<https://www.finnex.net/customer-service>